

Title:	Cross Country Guidelines		
Ref. No:	EA-Eventing-GL-01	Issue Date:	08/2020
Next Review Date:	01/2023	Version No:	V1.5
Applies to:	All EA Officials		
Authorised by:	Equestrian Australia Eventing Committee (EAEC)		
Related Legislation / Guidance Material:			
1) EA Rules for Eventing (25 th Ed. 1/1/2022)			
2) FEI Cross Country Guidelines (06/01/2021)			



Cross Country Course Design Guidelines

These Guidelines are a reference point for Equestrian Australia (EA) officials. They are not a rule book or a stand alone document, but rather a supplementary guide alongside the EA Rules for Eventing 25th Edition (30/6/20) and the National Education Program.

These guidelines must be read in conjunction with the FEI Eventing Cross Country Guide for Officials (version 06/01/2021) and the EA Eventing Rules (25th ed. 01/01/2022).

The purpose of the Guidelines is to help with the designing and evaluation of cross-country courses and to help EA officials achieve the same standard and level of safety for horses and riders at all affiliated events.

Any fence built where the design falls outside of this guide should be to a standard for its level of competition and should be the subject of a discussion between the course designer (CD) and technical delegate (TD) who should be in agreement before the start of the competition that the question is appropriate. At events, it is always advisable to include the Rider's Representative in these discussions if at all possible, riders have great experience which should not be ignored or disregarded by Event Officials.

DEFINITION OF JUMPING EFFORT

An effort is any fence/obstacle that requires a horse to make a jumping effort. At 60/65cm and 80cm, a walk through water should be flagged and counted as a jumping effort. At 95cm through 4*, a walk through water may not be flagged and not counted as an effort.

OBSTACLES WITH ALTERNATIVES

An obstacle with one or more alternatives should be counted as one effort as long as the CD and TD agree that the average horse will take the direct route.

Dimensions of alternatives should be in accordance with the level and where possible the 'Black Flag' rule should be used to create smooth lines and 'flow.'

Alternatives with extra efforts are better than requiring horses to do a circle as part of an alternative route.

HEIGHTS AND OBSTACLES

With the exception of the first fence and where detailed in these guidelines, all fences at every level should be built to maximum dimensions.

As a guideline, fences on a down slope, before a step, ditch or other unexpected situation should be around 5cm below maximum height.

Fences should always be measured on the intended jumping line. CDs and TD's should also take this into account when measuring top and base spreads.

The rule does not mean that all parts of a fence between the flags has to be within height limits, but rather all parts that the CD and TD expect the average horse and rider to jump.

General Guidelines

- No fence can ever be justified by the use of an alternative(s) or frangible technology.
- No fence can be jumped in two directions unless it is a 'Black Flag' and then only if it is not frangible.
- All frangible fences must be jumped in the direction of the flags.
- All courses should be measured fairly and reasonably on the 'riding line.'
- CDs should never try to 'catch horses out,' surprise horses, or use unfair distances, but rather always give horses two or three strides to understand the question and offer a positive experience.
- All courses should be preparing horses and riders for the next level of competition, therefore need to be at the appropriate level of difficulty.
- CDs should be looking to show horses what they can do, not what they can't, at every level.
- All courses should 'flow' and allow riders to maintain a good rhythm. CDs should not attempt to slow horses down at the expense of flow.
- Wherever possible have turns before a fence to help the horse's balance rather than after fences.
- CDs must encourage the average rider on an average horse to produce a good 'picture.'

ANCHORING FENCES

Just because a fence is heavy it can never be assumed that it won't move when hit by a horse. If a fence moves it significantly increases the chance of a rotational fall. All fences must be anchored into the ground and rendered immobile to keep the fence from flipping or sliding.

It is not acceptable to anchor any fence at any level with one anchor in the middle at the front. A minimum of two anchors per jump should be used and the bracket should be fastened to an integral part of the fence with 4 screws.

FRANGIBLE DEVICES

Please refer to the EA Rules For Eventing and inside fei.org/fei/disc/eventing/risk-management/devices

The use of a frangible device cannot justify the use of the wrong fence in the wrong place.

OVERHEAD HAZARDS

As we design, build, prepare, and inspect courses it is very important to look out for overhead hazards that may not be immediately obvious on both the direct line and, if there is one, on the line to be taken on a long route/option. Such hazards (ex: tree branches, roof, keyhole) can cause a competitor to be knocked from their horse and be seriously injured. The CD and TD need to agree the best course of action to deal with any such instances whether it is removing the hazard or preventing horses passing underneath it.

Horse Vision

Horses are dichromatic and therefore see in contrast, believed to be in shades of yellow and blue as opposed to humans who are trichromatic and see in color. Therefore, the contrast between the top of the fence and the background are of paramount importance.

It is believed that horses take up to seven times longer than humans to adjust from light to dark and vice versa. CDs should therefore be very aware of shadow and light into dark. Horses should have at least two strides to adjust in the 'dark' before a fence.

Horses are prey animals that can see through 340 degrees but cannot see 10 degrees in front or 10 degrees behind. This means that in the last 5m the horse gains more and more information from the sides and less and less from directly in front.

Decoration on the top corners of spread fences help the horses to read the front and back of spreads. A pair of flags set in the middle of a spread fences with no other decoration is not advised as the flags take away from the horses ability to read the leading edge.

Any decoration in front of the leading edge (trees, shrubs) helps the horse to read the leading edge and therefore helps to keep the horse away from the leading edge.

Illustration of Measurements

From the FEI Eventing Cross-Country Guide for Officials

TOP SPREAD

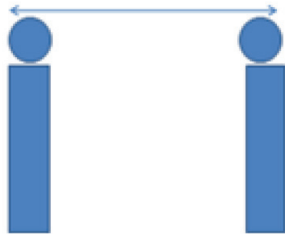
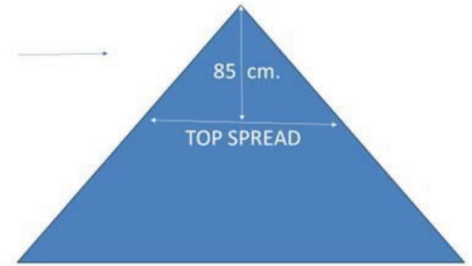
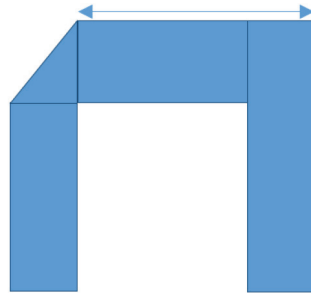
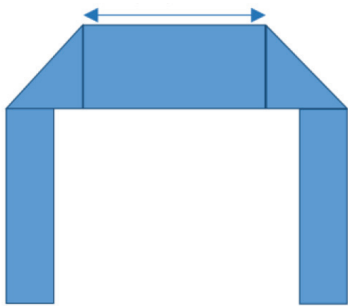

OUTSIDE TO OUTSIDE

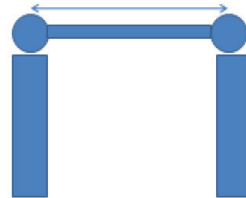

HIGHEST POINT TO HIGHEST POINT

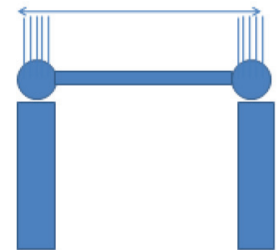

Outside to Outside of Brush

BASE SPREAD

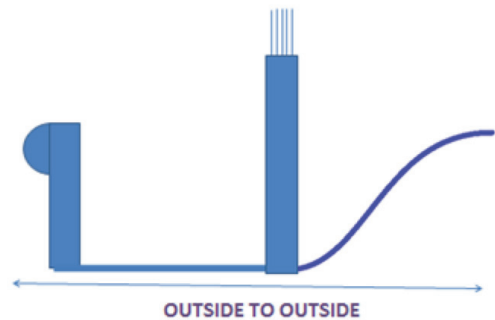
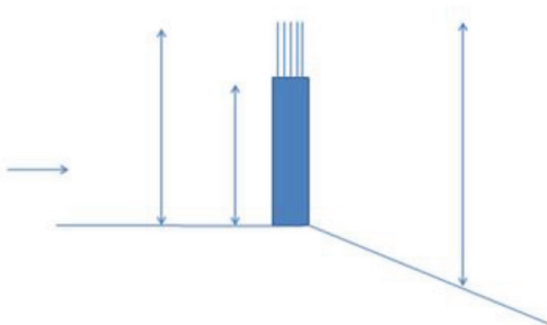
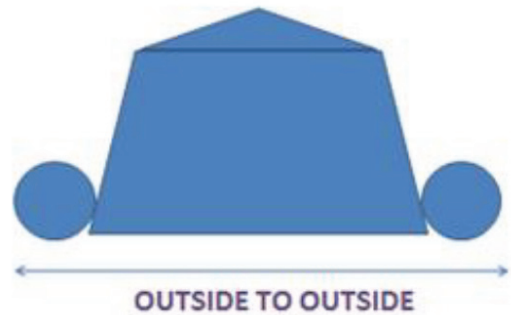
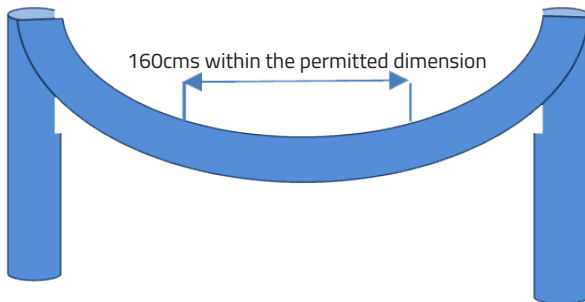

DIMENSIONS OF OBSTACLES

Please refer to Annexe B, Specification for Horse Trials in the EA Rules For Eventing.

GROUND LINES

All fences have an anticipated speed depending on terrain, direction of approach, profile of jump, etc. The average take off point is directly related to the anticipated speed and height of the leading edge of the jump. The ground line is part of the overall base spread dimension and should not exceed the max. base spread according to EA Rules For Eventing Annexe B. There should be no grass/dirt between the ground line and front of fence, where the horse might put a leg down.

Ground lines are intended to help horses read the fence and identify the leading edge. Ground lines should be used to improve the profile of fences and to help prevent horses getting too 'deep' to a fence:

- Unless there are exceptional circumstances, ground lines should always be used on fences from 1* up;
- It is expected for there to be a discussion between the TD and CD as to the type of ground line to use;
- Ground lines can be rails, flowers, plants mulch/woodchip, it can be offcuts or anything suitable that will help or further improve the profile of a fence. It need not necessarily extend all the way along the front of the fence, but must remain consistent throughout the day;
- Ground lines should be used on steps out of water;
- A single rail must never be used without a groundline;
- False groundlines are not acceptable under any circumstances (a false groundline is defined as when the groundline is behind the vertical plane of the front of the fence), care must also be taken that the substructure of the jump does not draw the horse's attention and create this false groundline.;
- Groundlines should stay consistent through the entire competition.

COMBINATIONS AND RELATED DISTANCES

Combinations of four strides or less should be on a true distance. A true distance relates to the average strides a horse would take between elements. The CD and TD both should be in agreement that the average horse should arrive at a related fence on a normal stride from the previous fence, not a half stride. There are numerous factors that will determine a true distance including the slope of the land (uphill, downhill, flat), the profile of the fences (upright vs steeplechase style fence), the likely speed of approach to the fence (coming from a gallop across a flat paddock as opposed to coming off a turn after an incline).

At 1* and above all four stride combinations are jumped at approximately 400-450mpm. As the distance controls the length of the stride and speed, CDs should understand that at 300mpm the horse will take a shorter stride and at 500mpm a longer stride. Therefore the anticipated speed of approach is critical at every related distance.

BENDING LINE COMBINATIONS

The diagram to the right is a guide to the recommended number of strides between elements with top spread at different angles between fences. This is intended to help with the flow of bending lines so that horses are not pulled about between fences.

The diagram clearly shows that for instance, in a 95cm class the CD can use 8 strides to complete a 90 degree bend and so on.

It is accepted that horses take a slightly shorter stride on a bending line than when they are on the straight away.

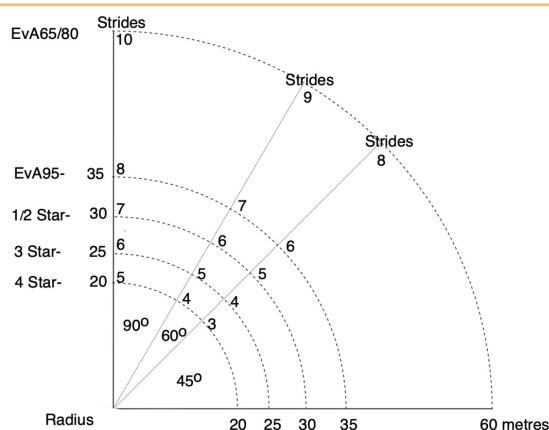

APPROACH

- Upslope – easier for a horse to jump.
- Downslope – more difficult for a horse to jump so the height of a fence on a downslope should normally be 5cm below maximum.
- Straight – more difficult for the rider to balance the horse.
- Off a turn – easier for the rider to balance the horse.

The length of a horse's stride will tend to lengthen on a gentle downslope, so those fences will need a bigger ground line. Similarly the length of stride on a gentle upslope will tend to shorten the horse's stride, therefore, less ground line required. The faster the anticipated approach the longer the horse's stride. See Ground Lines. With a steep slope up or down the horse's stride will shorten. The switchover must be a discussion between the CD, TD, and Ground Jury when looking at related distances and the size of ground lines.

Introducing Horse & Rider to Eventing: EvA60/65 & EvA80

OBJECTIVE

The EvA60/65 and EvA80 classes serve as an educational step for riders and horses of all ages, towards competing and experiencing events at the lowest level and offering the benefit of the highest standards of course design and building.

Riders should be able to canter around the course in a good rhythm. They will be expected to be able to go up and down hills/slopes and to jump a variety of straightforward fences.

These classes need to cater for '60/65 and 80 only' competitors as well as those who will use it as an educational stepping stone to progress up the levels. Time on course is not expected to be a key element at these levels. It is intended that these guidelines be used to create a base standard for the EvA60/65 and EvA80 classes. Advice from Technical Delegates is helpful during the design, construction and alteration of courses.

DESIGN & CONSTRUCTION

At this grassroots level, the variety in the way that obstacles appear and their profile is very important. Obstacles, which have a sympathetic and more forgiving profile, should be used wherever possible. All obstacles should have well defined ground lines and their jumpable width should be wide and inviting. Courses should have a good balance of fences and the first six fences should encourage horses to jump confidently and in a rhythm.

The inclusion of more upright fences: post and rails, is appropriate and educational but care should be given in the correct positioning of upright fences, including a 45 degree leading edge and suitable ground lines. Each individual jump should be a question on its own.

By placing obstacles too close together does not allow the inexperienced horse or rider to understand clearly the question asked and therefore confidently tackle the obstacle. Examples are: placing a jump before a water complex, a question of a turn with undulating terrain, not enough distance between obstacles and narrow obstacles in related lines.

COMBINATIONS & RELATED DISTANCES

EvA60/65 classes do not necessarily require combinations, if they are used it should be limited to two combinations.

It is recommended there be a maximum of three combinations within the course for EvA80, excluding the water fence. Combinations should not appear before fence 4 wherever possible to allow sufficient time for competitors to have warmed up before any questions are asked.

(A Combination is defined as elements with two or less non-jumping strides in between. Related distances refer to distances above two non-jumping strides).

Combinations should be simple and straight forward consisting of not more than two elements. Sympathetic fence profiles should be used. Avoid using fence types which can jump erratically and alter distances between elements e.g. brush fence as the first part of a combination.

Combinations and related distances should not be sited at the end of long galloping stretches, on a downhill slope or in an area with a confined access or exit. Avoid areas in shadow or with poor light. A slow measured approach should be the designer's aim.

Bounce distances without height should not be used at these levels, unless a significant discussion has taken place between the Technical Delegate and Course Designer.

The Next Level:

EvA95 & 1*

OBJECTIVE

The EvA95 and 1* classes are to train inexperienced riders and horses by giving positive experiences producing confident and educated athletes, with the benefit of the highest standards of course design and building.

EvA95 Riders should be able to canter around the course, in a good rhythm. They will be expected to be able to go up and down hills/slopes and to jump a variety of straightforward fences.

1* is to encourage less experienced riders and horses to compete in and enjoy the demands of EA Eventing before progressing up the levels.

The course should be inviting and flowing with obstacles evenly spaced throughout, thereby reducing long galloping stretches. The course as a whole must be consistent and demanding enough that a successful competitor could progress to 2* with confidence, yet inviting enough to allow riders and horses, not yet ready for 2* to gain confidence. It needs to be recognised and understood that many riders do not have the ambition to progress above this level. Competitors will be expected to jump the course in a rhythm over a variety of straightforward fences including going up and down slopes and undulations.

The EvA95 class needs to cater for '95 only' competitors as well as those who will use it as an educational stepping stone to progress up the classes. Time is not expected to be a key element at EvA95 level. It is intended that these guidelines be used to create a base standard for EvA95 level.

At 1* time begins to become a factor in the context of the competition. These guidelines are intended to create a base standard for the 1* class.

DESIGN & CONSTRUCTION

At this grassroots level, the variety in the way that obstacles appear and their profile is very important. Obstacles, which have a sympathetic and more forgiving profile, should be used wherever possible. All obstacles should have well defined ground lines and their jumpable width should generally be wide and inviting. Courses should have a good balance of fences and the first six fences should encourage horses to jump confidently and in a rhythm.

The inclusion of more upright fences: post and rails, is appropriate and educational but care should be given in the correct positioning of upright fences.

The variety of fence design and materials used in construction plays a significant part in educating horses and riders in what they will face as they progress through the different classes. Courses should have a good balance of fences and the first four fences should encourage horses to jump confidently and in a rhythm.

All obstacles should have ground lines with their jumpable width as wide and inviting as possible. Approximately 75% of fences not asking a specific question (i.e. straight forward fences) should be as close to maximum dimensions as possible.

Fences that restore confidence should be used after combinations or more difficult questions.

DISTANCES

Bounce distances, on fences with height, should not be used at this level. A bounce distance between two steps is permitted. If using a bounce, an alternative should always be presented to the horse and rider.

ALTERNATIVES

Alternatives should not be necessary as the direct route should be suitable for the majority of competitors. Where they are considered necessary, they should be asking the same type of question as the direct route e.g. accuracy, be the same in construction (where possible) and be easier and more time consuming to execute.

COMBINATIONS & RELATED DISTANCES

At EvA95 there should be a maximum of three combinations within the course, excluding the water fence. They should appear in the last two thirds of the course, wherever possible, to allow sufficient time for competitors to have warmed up before any questions are asked. Combinations should not appear before fence 4.

(A Combination is defined as elements with two or less non-jumping strides in between. Related distances refer to distances above two non-jumping strides.)

Combinations should be simple and straightforward consisting of not more than two elements. Sympathetic fence profiles should be used.

Avoid using fence types, which can jump erratically and alter distances between elements e.g. care should be taken when using brush fences as the first part of a combination. Combinations and related distances should not be sited at the end of long galloping stretches, on a downhill slope or in an area with a confined access or exit. Avoid areas in shadow or with poor light.

A slow measured approach should be the designer's aim.

At 1* the design of combinations and related distances should start to incorporate a variety of different obstacle profiles. In introducing slightly more technical combinations and related distances, kinder profile obstacles should be used e.g. logs, in order to give a more positive experience.

Avoid using fence types which can jump erratically and alter distances between elements e.g. care should be taken when using brush fences as the first part of a combination.

Separately numbering obstacles, rather than ABC lettering, is a useful design tool to help the inexperienced and is strongly recommended where appropriate.

WATER OBSTACLES

EvA95 competitors should be expected to negotiate a simple 'dew pond' type complex, with a ramp into and out of water or a simple drop into a water.

Obstacles placed before a ramp into water for EvA95 should be one to two non jumping strides or more. Fence profiles should be sympathetic. Maximum height fences should be avoided.

Obstacles after a ramp out of water for EvA95 should be sited one to two non jumping strides or more. Fence profiles should be sympathetic and avoid maximum height fences. Steps out of water are acceptable, and must be well defined. Consider painting the top of the step out with a suitable defining colour and/or a log groundline.

1* competitors can be expected to negotiate a variety of options.

For 1* Obstacles placed before a ramp into water, should be on 1 non-jumping stride or more. Fence profiles must be sympathetic. Maximum height fences should be avoided.

Obstacles placed before a step into water for 1* should be on at least 2 non-jumping strides from the edge of the step. Fence profiles must be sympathetic. Maximum height fences should be avoided.

For 1* obstacles after a water complex can be placed after a ramp or step out. Obstacles should be on one non- jumping stride or more. Jumps into water should not have significant height.

TABLES

All tables should be filled in with a sloping front face, with such face sloping away from the horse on the take off side of the fence.

NARROW FENCES

Narrow fences should be introduced at EvA95 level to encourage accuracy. There should be a maximum of 3 minimum jumpable width fences. (Jumpable width is defined as between the flags). The minimum jumpable width should be 2.00m.

This should be made more inviting with the use of trees and dressing to create an impression of width and to help guide competitors in. In the case of brush fences cutting in a 'scallop' shape creates such an impression.

The education started at EvA95 should be built upon at 1* level. We should be setting the horse and rider an increased test of accuracy while still allowing for less experienced horse and rider combinations. There should be a maximum of 3 minimum jumpable width fences. (Jumpable width is defined as between the flags). The minimum jumpable width for 1* should range between 1.8m to 2.0m depending on contour of the ground and the location of the fence in relation to others on the course.

This can be made more inviting with the use of trees and dressing to create an impression of width. Some help can be given but learning to negotiate narrow fences is essential for progression.

FRANGIBLE FENCES

If fences at EvA95 meet the criteria for frangibles, it is recommended that a frangible device be used if resources allow.

If not, it is advised to change the obstacle by filling in the top or changing the size of the material.

For CCN1*, it is mandatory to use frangible devices on obstacles that fit the criteria from January 2021.

For All Levels

FRONT SHOULDER OF SPREAD FENCES

Since 1st January 2020, it has been included in the Eventing rules that all CDs should reshape spread fences with upright fronts so that the top of the front of the fence, will be rounded or sloped. It is required that the slope should be 45° (with a margin of +/- 5°) to a point 20cm, below the top of the leading edges.

For 95cm and below, it is recommended that the slope should be 45 degrees to a point of 10-15cm below the top of the leading edges.

If a fence has a sloping back, the back edge should follow the same principles as the front edge.

HAZARDOUS MATERIALS

There is a danger in using corrugated iron in fence construction for houses/shelters etc. In the event that the fence is damaged so that the edge of the iron sheeting is exposed it has the potential to cause extreme harm with what is effectively a sharp edge.

Particular care should be taken wherever this material is used and a reasonable assessment of the structure should be undertaken as follows:

1. The frame must be sufficiently robust to prevent deformation in the event it is hit by a horse;
2. The underside of the iron is supported by sufficient timber to prevent deformation in the event the fence is "banked";
3. All edges are concealed by timber capping of sufficient strength that will not easily break in the event of a horse hitting it.

Older fences should be checked carefully for deterioration in what may have originally been a sound structure

If there is doubt as to any of the three points above the fence should be replaced

Core Cross Country Elements

1*

It is envisaged that each course should have a minimum of 5 core fence types at least 2 of which must be ones marked below with a *. Each course should have a water fence and so this is not included in the list of core fences. There should be a minimum of 4 combinations/series of related fences

Core Fence types:

- Max spread fences
 - Brush fences
 - Drop fences
 - Sunken Road
 - Trakehner* and/or Open Ditch* (*ditch with brush or palisade behind*)
 - Ditch/Rail combination*
 - Corner/Narrow* (*no more than 4 at this level*)
 - Bank* (*step up and/or down combination*)
-

2*

It is envisaged that each course should have a minimum of 5 core fence types at least 2 of which must be ones marked below with a *. Each course should have a water fence and so this is not included in the list of core fences, and each course should have narrow fences. There should be a minimum of 4 combinations/series of related distances on the course. Obstacles in water are acceptable. A bounce may be used at this level but it is not core fence type.

Core Fence types:

- Max spread fences
 - Brush fences
 - Drop fences
 - Sunken Road *
 - Trakehner* and/or Open Ditch* (*ditch with brush or palisade behind*)
 - Ditch/Rail combination*
 - Corner/Narrow* (*no more than 4 at this level*)
 - Bank* (*step up and/or down combination*)
-

3*

There should be a minimum of 5 combinations/series of related fences on the course. Obstacles in water are acceptable. A bounce may be used at this level but it is not core fence type.

Core Fence types:

- Max spread fences
 - Brush fences
 - Drop fences
 - Sunken Road*
 - Trakehner* and/or Open Ditch* (*ditch with brush or palisade behind*)
 - Ditch/Rail combination*
 - Corner/Narrow* (*no more than 4 at this level*)
 - Bank* (*step up and/or down combination*)
-

4*

There should be a minimum of 7 combinations/series of related fences on the course.

Fences

WARM UP FENCES

Appropriate for all levels.

Officials should ensure that there is a minimum of two fixed fences with one designed to get the Horses jumping freely forward and the other a skinny and two show jumps including an upright and an oxer.

Care should be taken to make the area large enough that 3-4 horses can easily canter around at cross country speed.

It is the responsibility of the CD to check that the warm up fences are dressed and secured properly, including the track to and from the warm up and cool down areas. Officials must check the warm up fences as though they are competition fences.

UPRIGHT/VERTICAL

An upright fence where the lower rail(s) is/are in front of plane of the top rail. At 95cms if safety can be enhanced by making an upright fence frangible, and the rail dimensions and weight fit the acceptable parameters of an approved frangible device, CDs are encouraged to do so.

Vertical are a gate or similar fence e.g. rails on top of each other. Verticals are inappropriate at 1* and below-they may be carefully introduced at 2* and above.

BANKS (Cornish, Irish, and Normandy)

Not appropriate for 60/65cm, 80cm, and 95cm.

If a Cornish Bank can be jumped in one effort, the rails need to be within maximum dimensions.

An Irish Bank must have a retaining wall (wood or stone) on both sides. This should be approximately 60cm – 75cm as the exercise is to jump up on to the face of the bank, take a stride(s) over the top, and jump off.

A Normandy Bank has a step (see steps) and then a bounce (2.7mts to 3.3mts) for 4* only or a one stride (5.4mts to 6mts) for 1*, 2*, and 3*.

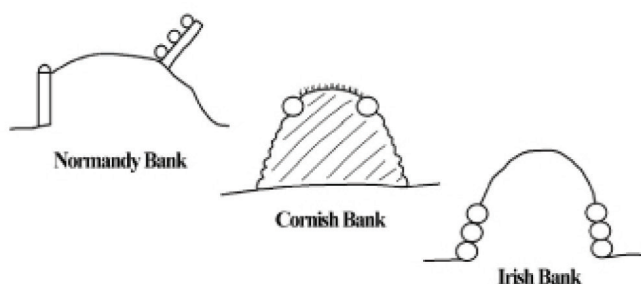

OXERS

The front profile of an oxer should be the same as an upright.

For 60/65cm, 80cm, 95cm and 1* the back rail should be a minimum of 5cm higher than the front rail. For 95cm and above it is recommended to use the MIM Clip front and back, if resources allow.

For 2* and above the back rail should be a minimum 5cm higher than the front rail.

At all levels there should be a visual contrast between the front and back rails.

BANKS (Step Up/Step Down)

Appropriate for all levels.

At all levels the height of the step up onto a bank should be at least 10cm below maximum.

60/65cm and 80cm should have a minimum of three strides across the top (13.7mts).

95cm and 1* should have a minimum of one or two strides across the top (5.4mts to 10mts).

2* and above should have a minimum of 5.4mt across the top.

BENCH/SEAT

Appropriate for all levels.

A sloping back to the seat is preferable.

The seat should be no more than 1/3 the height of the fence and the depth of the seat, from the front of the seat to the front of the top, should not exceed 2/3 the height.

BRUSH BOX/FRAME

Appropriate for all levels.

The height of the brush box should be 10cm below maximum at the front and 15cm at the back.

At all levels 25-30cm of brush is recommended above the height of the box/frame.

Brush Frame is always safer, as the back of the frame is lower than the front, not allowing a horse to slide a leg into frame.

BULLFINCH

Not appropriate for 60/65cm, 80cm, and 95cm.

The height of the box (frame) is the same as for a normal brush fence.

The see through brush should be approximately 60-90cm higher than the brush and must be of only token thickness for 1* and 2*.

CABIN/FEEDER/ROOF SHAPE

Appropriate for all levels.

The slope on the roof should be approximately 45 degrees.

A roof shape with a question beyond (water, ditch, step, drop, etc) should have a 'short back' i.e. 50% of the depth, compared to the front.

HOLLOWS

Not appropriate for 60/65cm.

80cm can have a half hollows with a fence before or after the ditch. A half Hollows is defined as two efforts only, a jump before the ditch or the ditch before a jump, it is recommended to have the fence before the ditch.

The height of the element before the ditch should be 5cm below maximum for all levels. The height of the element after the ditch should be maximum for all levels.

Ditch should be approximately 60cm deep. Distances will vary with slope, downslope – longer, upslope – shorter. Distances on flat ground:

LEVEL	DISTANCE BEFORE DITCH	DISTANCE AFTER DITCH	DITCH WIDTH
EvA80	13.3mts	13.7mts	75cms
EvA95	9.15mts	10mts	1.1mts
1*	5.4 - 9.15mts	6.4 - 10mts	1.2mts
2*	5.4 - 9.15mts	6.4 - 10mts	1.2mts
3*	4.5 - 5.4mts	3.2 or 5.4mts	1.4mts
4*	3.2 or 4.5-5.4mts	3.2 or 4.5-5.4mts	1.5mts

CORNERS

Appropriate for all levels.

All levels should have a tear drop ground line. A tear drop ground-line is described as a ground-line running at 90 degrees to the intended jumping line.

All 60/65cm and 80cm corners should be boarded in. For 60/65cm, 80cm, and 95cm, the back should be 5cm higher than the front.

The top spread of a corner at 60/65cm, 80cm, and 95cm should measure within 120cm from the apex of the corner.

At 60/65cm, 80cm, and 95cm levels, the top spread of a corner should be measured at 90 degrees to the bisecting angle.

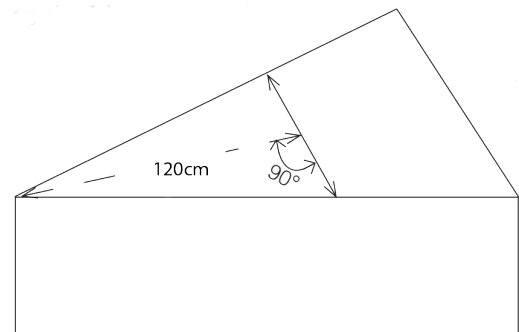

For 1* upwards, the back should be 2.5cm higher than the front.

The top spread of corners at 1*, 2*, 3*, and 4* should measure within 85cm from apex of the corner when jumping the bisecting line at 90 degrees.

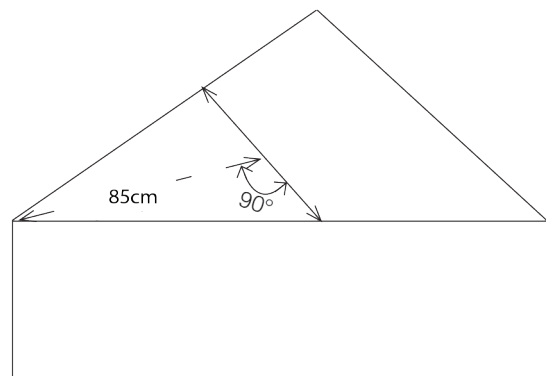

LEVEL	DEGREE OF ANGLE	TOP SPREAD
EvA60/65	15-20 degrees	120cm
EvA80	20-25 degrees	120cm
EvA95	30-35 degrees	120cm
1*	40-45 degrees	85cm
2*	45-55 degrees	85cm
3*	55-65 degrees	85cm
4*	70-80 degrees	85cm

DITCH BRUSH

Appropriate for all levels.

The height of the brush box frame should be 10cm below maximum at the front and 15cm at the back.

At all levels 25-30cm of brush is recommended above the box/frame. It is recognized that there is less risk to the horse with brush in a frame as opposed to brush in a box if the horse ends up in the ditch. 60/65cm and 80cm can have a scoop to create an insignificant (30-45cm) ditch behind a take off rail. For 95cm upwards the ditch should be 60cm deep and 4.2-4.8mts long. A base spread 30cm below maximum is recommended. This measurement must include the frame or structure of the jump and the guard rail at take-off.

If the ground is slightly rising in the last stride, this greatly helps the horse.

DOUBLE BRUSH

Appropriate for all levels.

The height of the brush box should be 10cm below maximum at the front and 15cm at the back.

The height of the brush at the front should be 5cm lower than the back.

All boxes should be decked in with a 5cm lip on the back to stop the horse from slipping into the second brush.

It is essential to fill in between the two rows of brush and to have a 1/4 or 1/2 round in front of the second brush on top of the fill.

TRIPLE BRUSH

Appropriate for all levels.

60/65cm and 80cm are normally two brushes not three. All brushes should be cut to produce a straight or concave(easier) shape.

Minimum dimensions:

LEVEL	WIDTH		HEIGHT		BASE SPREAD
	FRONT	BACK	FRONT	BACK	
EvA60/65	2.4mts	3.6mts	25cms	55cms	75cms
EvA80	1.8mts	3.3mts	30cms	70cms	90cms
EvA95	1.1mts	2.4mts	45cms	85cms	1.05mts
1*	75cms	2.1mts	45cms	95cms	1.2mts
2*	75cms	1.8mts	45cms	1mt	1.4mts
3*	60cms	1.6mts	45cms	1.05mts	1.6mts
4*	45cms-60cms	1.4mts	45cms	1.1mts	1.8mts

KEY HOLE

Not appropriate for 60/65cm, 80cm, and 95cm.

Solid box – see Brush Boxes

Top spread is not recommended, but should never be more than 50% of maximum.

There should be 60cm of brush between the top of the aperture and the solid part of the frame.

LEVEL	SIZE OF HOLE DIAMETER
1*	2.4mts
2*	2.1mts
3*	1.95mts
4*	1.8mts

NARROWS

Appropriate for all levels.

Narrows jumped on a bending line or at an angle should be 15cm wider than the minimum above. When a narrow is jumped from a straight approach or with a brush shoulder the jump can be at its narrowest.

At all times these jumps must be appropriate to their positioning and suitability in the course.

LEVEL	SUGGESTED MIN JUMPABLE WIDTH
EvA60/65	2.4 - 3.0mts
EvA80	2.2 - 2.7mts
EvA95	2.0 - 2.4mts
1*	1.80mt-2.00mt
2*	1.65mt-1.80mt
3*	1.50mt-1.65mt
4*	1.40mt-1.5mt

This is not to say that, provided the TD and CD are in agreement, fences cannot be narrower than this if they are jumped on a straight line or with a brush shoulder but this is not an excuse to have fences that are unsuitable for the level.

TRAKEHNER

Appropriate for all levels with an appropriate size log/rail for classes EvA95 and below, 1 and above must have a minimum 40cm diameter log*

60/65cm and 80cm should have a shallow scoop ditch under 95cm and above can have a reveted ditch that must be not more than 60cm deep.

Maximum base spread is not recommended at any level. Base spread should be proportional to the size of the log (bigger log = more base spread, small log = less base spread).

At all levels the take off should be defined by a prominent ground line.

OPEN DITCH

Appropriate for all levels.

All ditches other than 60/65cm should be approximately 60cm deep.

LEVEL	INSIDE WIDTH
EvA60/65	60-90cms (scoop)
EvA80	1.4mts
EvA95	2mts
1*	2.4mts
2*	2.8mts
3*	3.2mts
4*	3.6mts

PICTURE FRAME

Not appropriate for 60/65cm and 80cm.

Height of the solid, jumping part should be 2.5cm below maximum.

LEVEL	MINIMUM APERTURE
EvA95	2.4mts x 2.4mts
1*	2.25mts x 2.25mts
2*	2.1mts x 2.1mts
3*	2mts x 2mts
4*	1.8mts x 1.8mts

STEPS

Appropriate for all levels.

At all levels the height of a step up should be 10cm below maximum.

At 60/65cms a maximum of two steps with a minimum of one to two strides (6.4-10mts) between is recommended.

At 80cms a maximum of two steps with a minimum of one stride (6.4mts) between is recommended.

At 95cms a maximum of two steps with a minimum of one stride (6.4mts) between is recommended.

At 1*/2* a bounce (2.7-3mts) can be introduced between steps.

Three steps up with a bounce are not recommended at any level.

At any step combination, if the ground rises slightly between the steps it helps the horse read the question.

In an appropriate situation and after discussion with the TD, variations to the steps table could be made but must be noted in the TD report.

HELSINKI

Not appropriate for 60/65cm.

The height in the middle of each section should be 5cm below maximum.

LEVEL	JUMPABLE WIDTH
EvA95	Not less than 3.3mts
1*	Not less than 2.4mts
2*	Not less than 2.1mts
3*	Not less than 1.8mts
4*	Not less than 1.5mts

TABLE

Appropriate for all levels.

All levels must have either a sloped or rounded leading edge of approximately 45 degrees to a point 20cms below the top of the table at the front.

Where the leading edge is less than 20cm below the height of the obstacle, that too should have a sloped or rounded edge.

For 60/65cm, 80cm, and 95cm the back of the table must be 5cm higher than the front and 2.5cm higher for 1* and above.

There should be nothing protruding from the front of a fence such as a half round which a horse may catch a leg on as it comes upwards in its jumping trajectory.

ROOFS

Not appropriate for 60/65cm, 80cm, and 95cm.

A fence under a roof should be no less than 2.5cm under maximum and if a table the front should be 5cm lower again.

A fence under a roof should not have more than 50% maximum top spread.

The lowest solid part of a roof must be a minimum of 2.2mts

Never use in association with water.

Use pale colors if fence is shaded.

ROUND TOP

Appropriate for all levels.

SHARKS TEETH

Appropriate for all levels.

SUNKEN ROAD

Not appropriate for 60/65cm and 80cm.

95cm and 1* could have half a sunken road, that is step in or out, with a ramp in or out. In both cases a fence should be not less than 9mts before the step or ramp and not less than 9mts after the step or ramp, and not less than 9mts between the step and ramp, and should always be on flat terrain.

2* can have step in and out with 6.4mts between steps and fence no less than 5.4mts before and after the second step.

3* can have step in and out with 6.2-6.4mts between steps with a fence no less than 5.4mts before step and 2.7-3.3mts or 5.4mts after the second step.

4* can have steps in and out with a fence no less than 6mts between steps, with a fence no less than 3.3mts before the step and 2.7-3.3mts or 5.4mts after the second step.

At all levels, rails or logs are best so that the horse can 'see through' them and understand the question better. All distances are 'inside distances.'

The height of first element should be 5cm below maximum.

The height of the last element should be maximum.

Height of steps – see steps.

At all levels distances should be adjusted for up slope (shorter), downslope (longer) and longer where the step up is smaller.

PALISADE/RAMP

Appropriate for all levels.

The slope of all palisades/ramps should be not less than 45 degrees or more than 60 degrees.

WATER

Appropriate for all levels.

60/65cm and 80cm – see EA Rules For Eventing.
Depth of water 30cms.

Height of fence into water should never be more than 5cm below maximum height.

LEVEL	MAXIMUM DROP
EvA80	90cms inc. height of 30cm ground rail
EvA95	1.1mts inc. height of 50cm ground rail
1*	1.4mts inc. height of 80cm obstacle
2*	1.4mts without brush 1.6mts if used with brush
3*	1.6mts without brush 1.8mts if used with brush
4*	1.8mts without brush 2mts if used with brush

Fences after a step out of water:

LEVEL	MINIMUM OF MTS
EvA95	9.2mts
1*	5.4mts
2*	5.4mts
3*-4*	2.7mts-3mts

Water crossings should be a minimum of 9mts across.

Any fence in water is appropriate for 1* and above and should have a minimum of 6mts of water before and should be 5cm below maximum height. A round shape is preferable but never more than 50% maximum top spread.

Where there is a jump into water and a revetted step out, the step must be not less than 13.7mts after the fence in.

All distances need to be proportional to the height of the step, smaller step = more distance, larger step = smaller distance. All steps out of water should have a ground line.

Australian Cross Country Designers

Name	Level	Phone	Email
Wayne Copping	FEI 3	0428 821 005	wcopping@bigpond.com
Sylvia Williams-Roberts	FEI 3	0407 377 299	rognsyl@gmail.com
Ewan Kellett	FEI 3	0418 527 856	kellettcrosscountry@yahoo.com.au
Vince Roche	FEI 3	0407 205 862	vroche@acenet.com.au
Stuart Tinney	FEI 3	0418 293 930	stuart@tinneyeventing.com
Grant Johnston	FEI 3	0417 887 116	grantj@nakuru.com.au
Darryl Burgess	FEI 2	0429 031 932	darryl.burgess@bigpond.com
Mick Pineo	FEI 2	0427 851 560	mickpineo@gmail.com

Document History

Author	Status	Date	Version	Approved Changes	Date Approved	Signature
Wayne Copping	Initial draft: discussed with Ewan Kellett, Mike Dalmau and Meredith Chapman	18.08.2020	1.0			
Wayne Copping	2 nd draft shared ED CD's	25.08.2020	1.1			
Wayne Copping	3 rd draft endorsed by EAEC and published	15.09.2020	1.2		26.10.2020	
Meredith Chapman	Publish on EA website	26.10.2020	1.2		26.10.2020	
Wayne Copping	Changes to jump definitions updated	18.11.2021	1.3			
Wayne Copping	Changes to jump widths updated	13.01.2022	1.4			
Wayne Copping	Updated rule editions	25.02.2022	1.5			